

DEGERtracker S100-PF-DR



SINGLE-AXIS TRACKING SYSTEM

Single-axis, active tracking systems from DEGER enable the optimal utilization of all the irradiation energy, suitable for all widely-sold solar modules. With the patented sensor-based MLD technology you can achieve yield increases of approx. 30% for all photovoltaic applications. An easy plug-and-play installation is

realized by means of the stable supporting construction. The decentralized control enables maximum independence. DEGERtrackers are "designed in Germany"- and stand for quality and durability.

Rating chart using a sunny summer day as an example

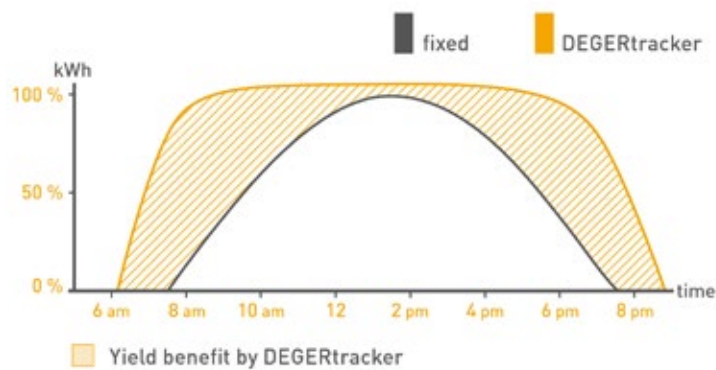

Advantages

- Yield increase with MLD-Technology
- Yield increase with snow sensor
- Fast and simple installation and easy handling
- Robust durable technology
- No linked of several tables
- Automatic reset in initial position at night
- Up to 100 trackers to be managed by one Central Control Box (CCB)
- Wind guard with anemometer, in storm conditions DEGERtracker is placed automatically in security position

Technology

- Efficiency with intelligent tracking
- Maximum Light Detection control concept
- Premium product from the global market leader
- Low consumption

Technical Specification

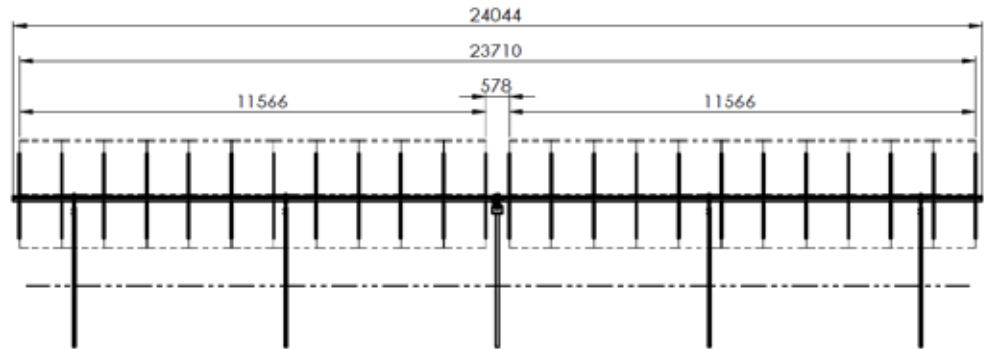

**DEGERtracker S100-PF-DR
with driven pile foundation ⁽¹⁾**

BASIC DATA

Nominal output (depending on module)	11,000 - 12,320 Wp DC
Tracking type	1-axis
Module surface up to	78,6 m ²
Max. module surface (W x H)	2 x 11,57 m x 3,4 m
60-cell Standard Module (max.)	44
Approvals	CE, UL

STRUCTURE

Materials	hot-dip galvanized steel, aluminum, synthetics
Galvanization	EN ISO 1461 or comparable
Bond-Type	bolted connection, no welt at sight
Certified statics	yes
Max. North-South slope	10°
Weight (without mast/aluminum)	project specific
Subsoil requirements	soil survey necessary

DRIVE

Principle	maintenance free screw drive
East-West angle	+/- 50°
Spin speed	18°/min.
Sound level (without load)	50 dB(A)
Protection class	IP 55

Technical Specification

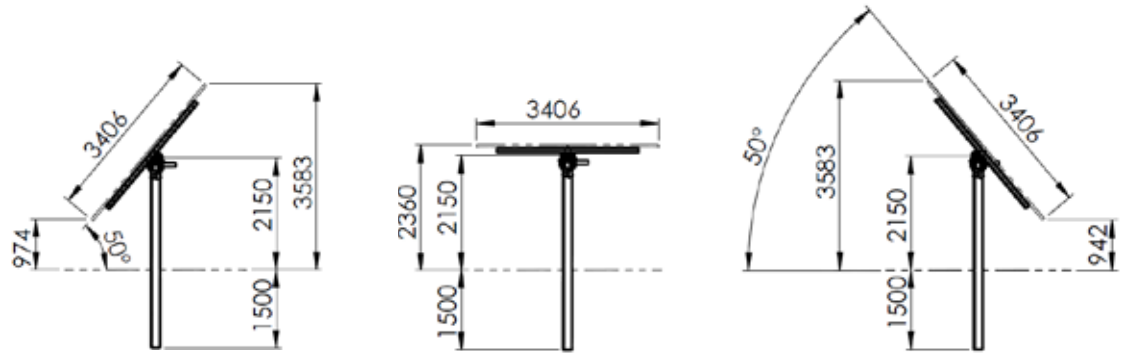

**DEGERtracker S100-PF-DR
with driven pile foundation ⁽¹⁾**

ELECTRONICS & CONTROL

Operating voltage	100 – 240 V AC / 50 – 60 Hz
Rated input current	2,3 A
Control	MLD-Technology
Protection class	IP 54

POWER CONSUMPTION (APPROX)

Control mode	1 W
With running actuator	50 W – 240 W
Internal consumption per year	5 kWh

POWER OUTPUT

Output voltage	24 V DC
Output current (max.)	10 A

CLIMATIC CONDITIONS

Installation over sea level	max. 2000 m
Permissible ambient temperature	-20°C – +50°C
Humidity range	5% – 95%
Permitted wind speed	110 km/h ⁽²⁾

⁽¹⁾ The depth of the driven pile foundation must be statically calculated

⁽²⁾ With full occupancy – Laid out with planing tool

SCOPE OF DELIVERY

Complete single-axis tracking systems, solar module carrier system made of aluminum, matching the module type used, patented control MLD (Maximum Light Detection) with MLD sensor, wind guard, snow sensor, foundation plan, assembly instructions.

OPTIONAL SERVICES

Extended warranty, on-site service, trainings.